

MANUAL 3

PROCEDURE FOLLOWED IN THE DECISIONMAKING PROCESS, INCLUDING THE CHANNELS OF SUPERVISION AND ACCOUNTABILITY.

Decisions are taken at unit level as well as at Police Headquarters level. At unit level, district S.Ps and Commandants, as the case may be, are empowered by Govt. rules and regulations; notifications to take certain decisions concerning their jurisdictions or units.

At Police Headquarters level, various and different level officers are empowered to take decisions on matters which are internal by nature. However, final decisions on policy and important matters having bearing on the Department as a whole are taken by DGP on the advice of officers assisting him. Whatever decisions taken are to be in consonance with the existing rules & regulations, norms and procedures. No officer is authorized to take arbitrary decisions not in conformity with the Government's stated policies, rules and regulations.

The organisational flow chart shown below will clearly make one understand the hierarchy, the channels of supervision and accountability.

HIERARCHICAL SET UP OF NAGALAND POLICE HEADQUARTERS

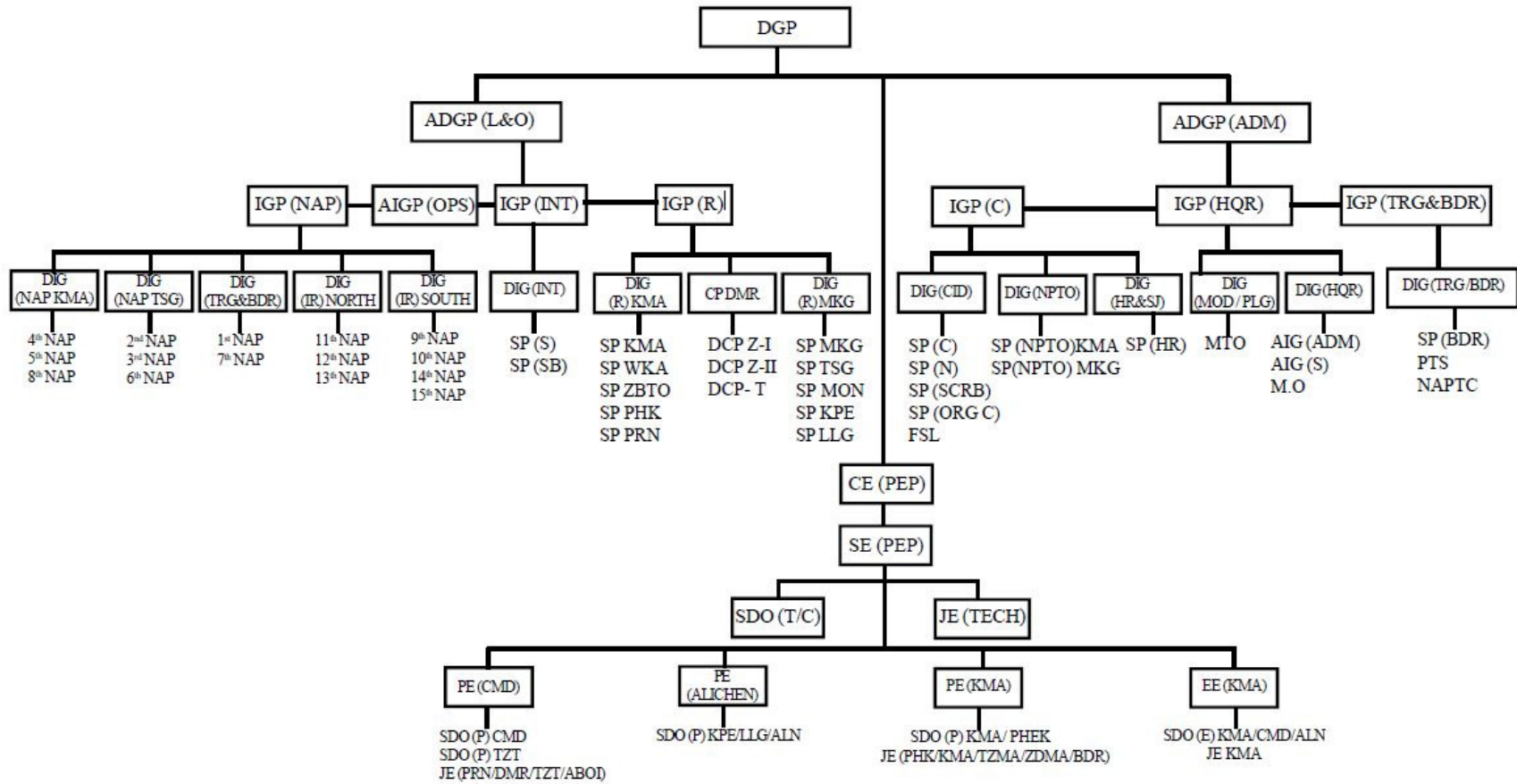

HIERARCHICAL SET UP OF IGP (INT) ESTABLISHMENT

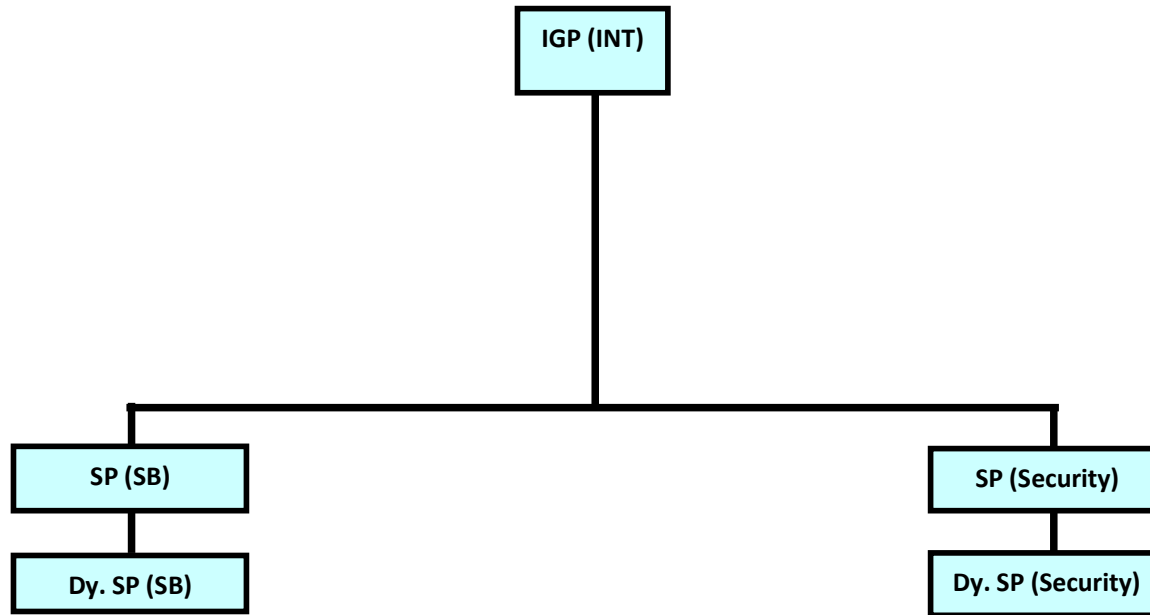

HIERARCHICAL SET UP OF DISTRICTS EXECUTIVE FORCE

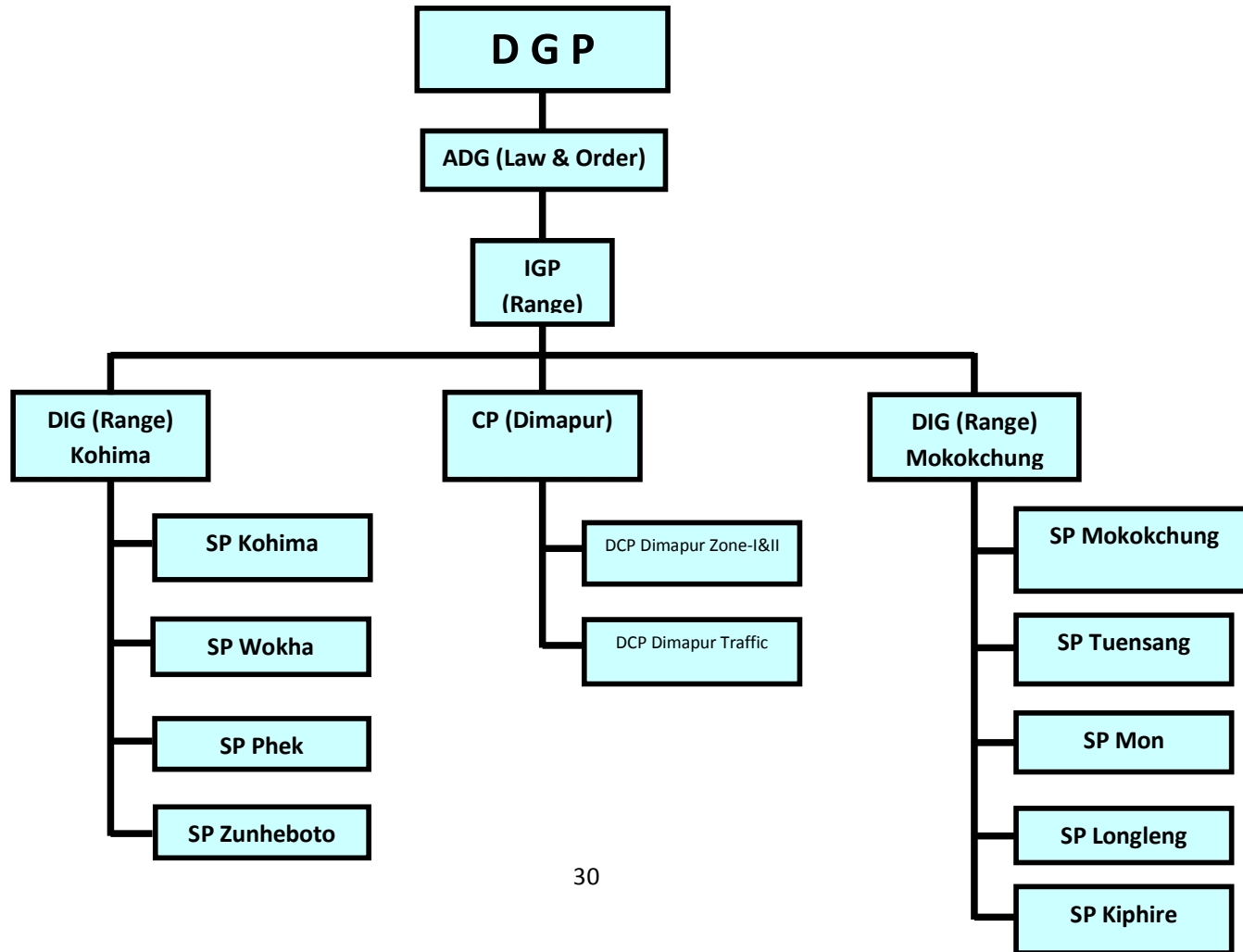

HIERARCHICAL SET UP OF NAP BATTALLIONS

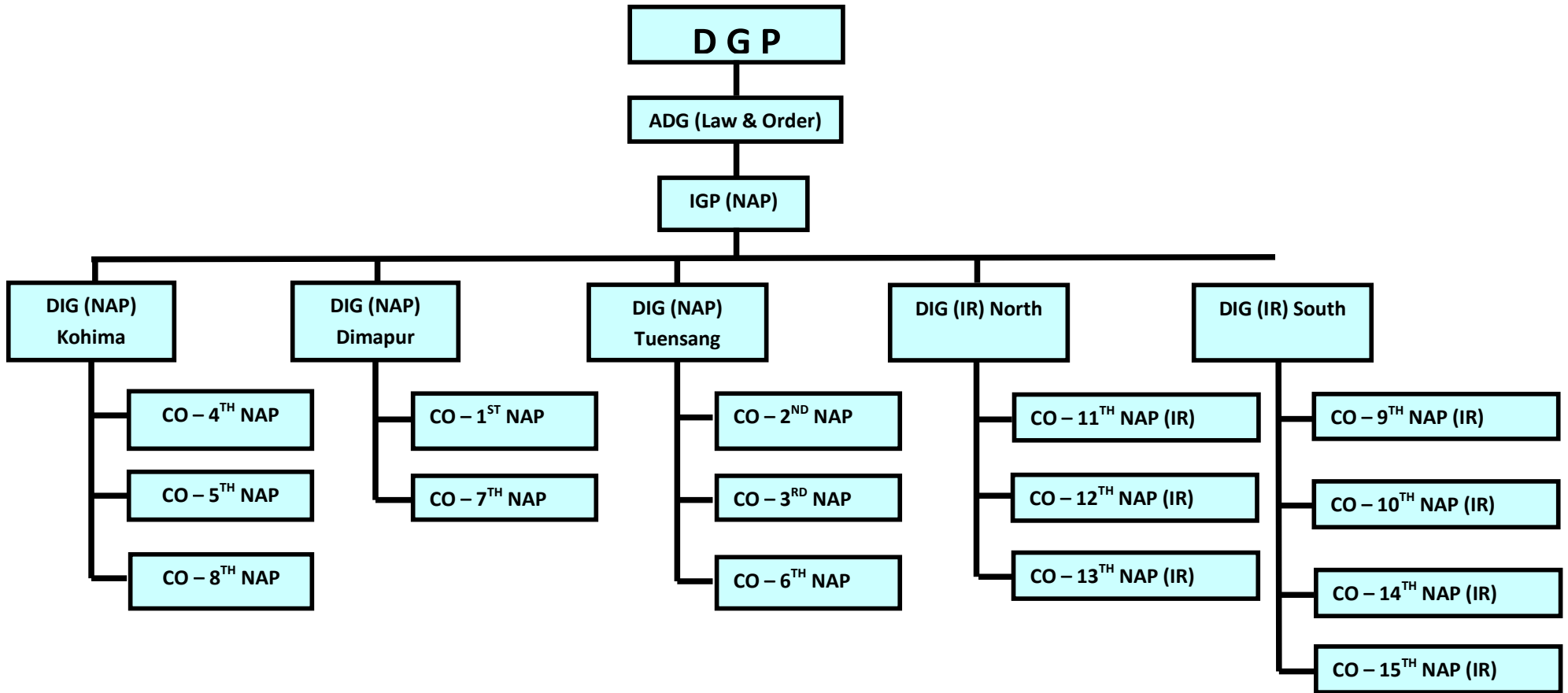

POLICE ENGINEERING PROJECT, KOHIMA

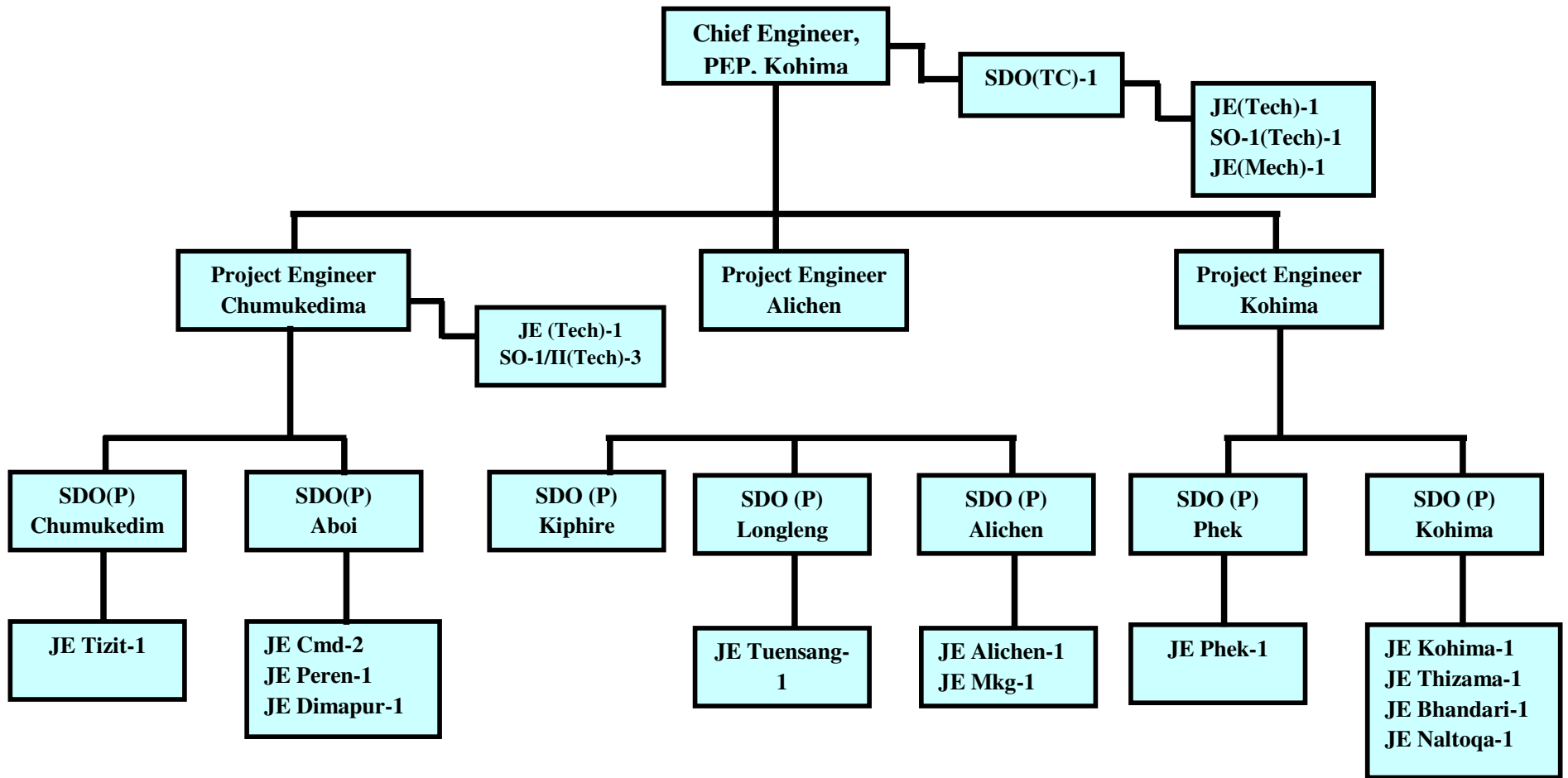

HIERARCHICAL SET UP IN NAGALAND ARMED POLICE BATTALION

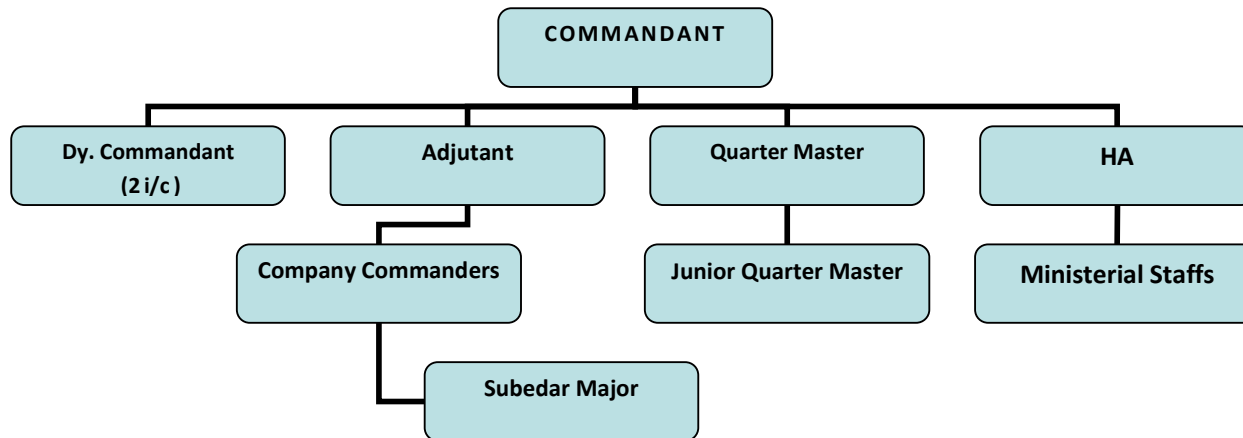

HIERARCHICAL SET UP IN DISTRICT EXECUTIVE FORCE

